

HomeRAB™
Pre-Cladding/RAB™ Board

Flexible flashing tape
dressed up and adhered
to HomeRAB™ Pre-
Cladding/ RAB™ Board
behind battens

Timber cavity batten

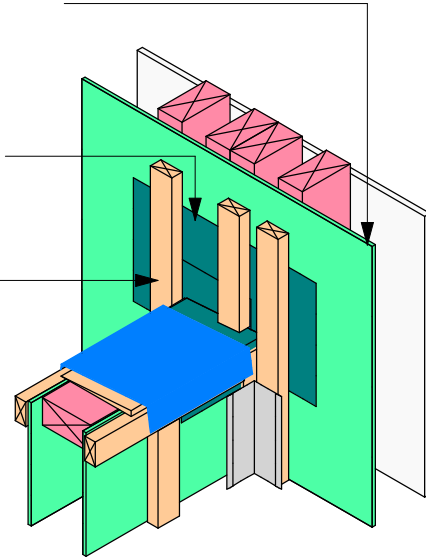

Saddle Flashing

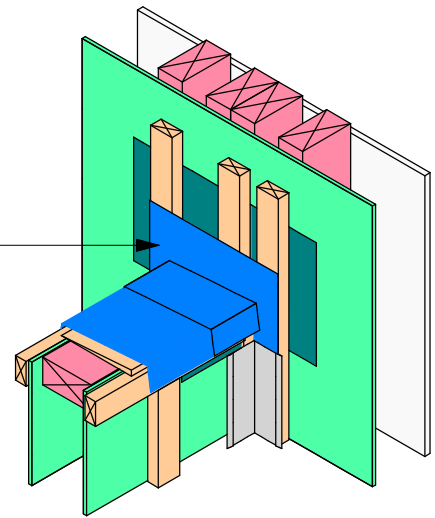

Studs

Oblique™ Weatherboard

Metal saddle flashing under
parapet capping refer
E2/AS1 Figure 12 for min
dimensions

Parapet flashing with underlay

Oblique™ Weatherboard
finish 5mm clear of cap
flashing. Apply flexible
sealant

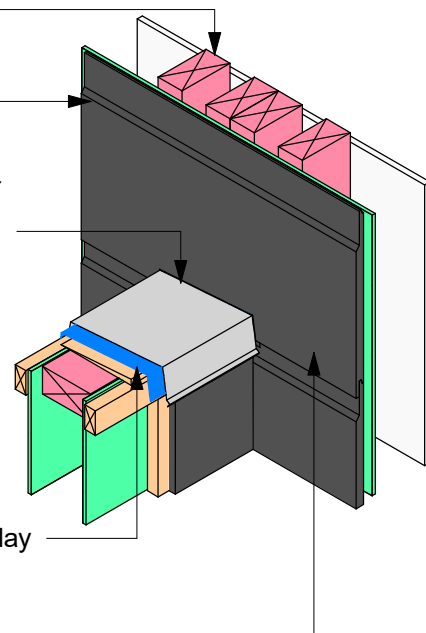

Plot Date: 28 May 2024 16:59

jhl_oblh14.rvt

October 2022
Scale:

jhl_oblh14_r_037c